



The Dolomite Centre Ltd
 Unit 1, Anglian Business Park, Orchard Road,
 Royston, Hertfordshire, SG8 5TW, UK

T: +44 (0)1763 242491
F: +44 (0)1763 246125
E: sales@dolomite-microfluidics.com
W: www.dolomite-microfluidics.com

Dolomite Microfluidics – North America Office
 Blacktrace Inc, 29 Albion Place
 Charlestown, MA 02129, USA

C: 617 803 6655
T: 617 848 1121
F: 617 500 0136
E: salesus@dolomite-microfluidics.com

INFORMATION SHEET

Part name	Mitos T-junction Platinum Chip with Header	Part number	3000089
-----------	--	-------------	---------

Description

The T-junction Platinum Chip is a glass microfluidic device designed for a range of applications including mixing fluids, microreactions and droplet formation. The platinum coating on the surface of the channel makes this chip ideal for various catalysis led reaction chemistries. The chip is supplied with a chip header (below). The header allows connection to the Dolomite Edge Connector (part number 3000024).

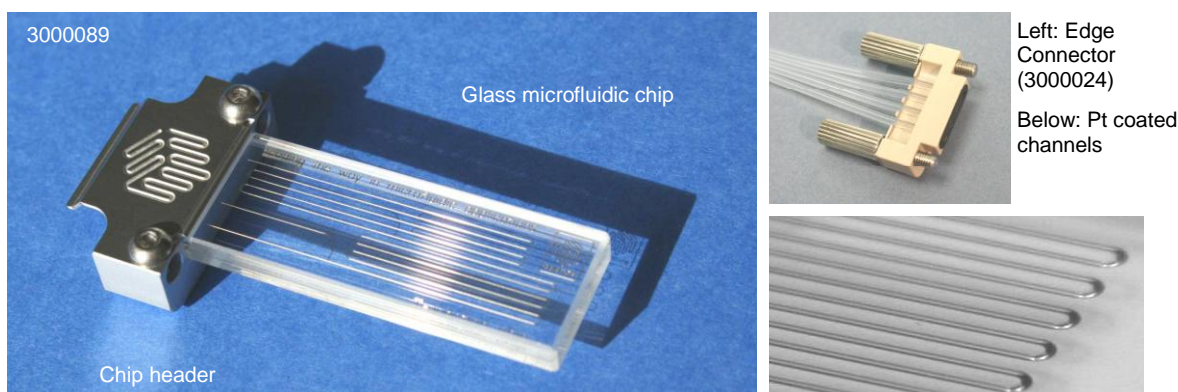

Benefits

- Compact
- Low dead volume
- Quick connect/disconnect
- Extremely high platinum surface area
- High visibility (excellent access for optics)
- Extremely smooth channel surface
- Wide temperature and pressure range
- Low cost
- Excellent chemical compatibility

	Chip Specification	Value
1	Number of inputs	2
2	Number of outputs	1
3	Internal channel cross-section	100 μm x 110 μm (depth x width)
4	Channel length after T-junction	278 mm (feed channels = 20 mm and 22 mm)
5	Volume of channel after T-junction	2.5 μl
6	Back pressure with 100 $\mu\text{l}/\text{min}$ flow (water)	1.5 bar
7	Surface roughness of channels (R_a)	5 nm
8	Chip size	45.0 mm x 15.0 mm
9	Chip top layer thickness	2.0 mm
10	Chip base layer thickness	2.0 mm
11	Platinum layer thickness	100 nm
12	Operating pressure	30 Bar with edge connector (higher with other connection methods)
13	Operating temperature	250° C with edge connector (higher with other connection methods)

14	Material	Glass and platinum
15	Fabrication process	HF etching and thermal bonding

Channel cross-sectional profile

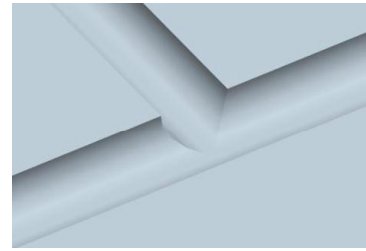
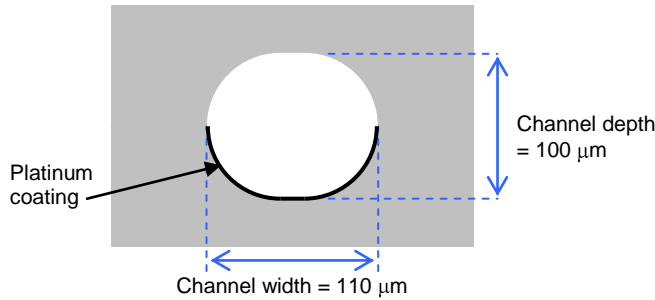

Image of T-junction (base layer only)

Custom options

The channel may be etched to different depths, for example from 20 μm x 30 μm up to 700 μm x 710 μm (depth x width). The top layer or base layer can also be left un-etched giving a semi-circular channel cross-section.

Custom channel layouts can also be specified.

Custom surface coatings

The glass channel surface is hydrophilic. The chip can also be supplied with:

- Hydrophobic coating on channel surface
- Platinum coating on top and bottom channel surfaces as shown below

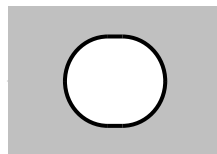

Edge connector geometry

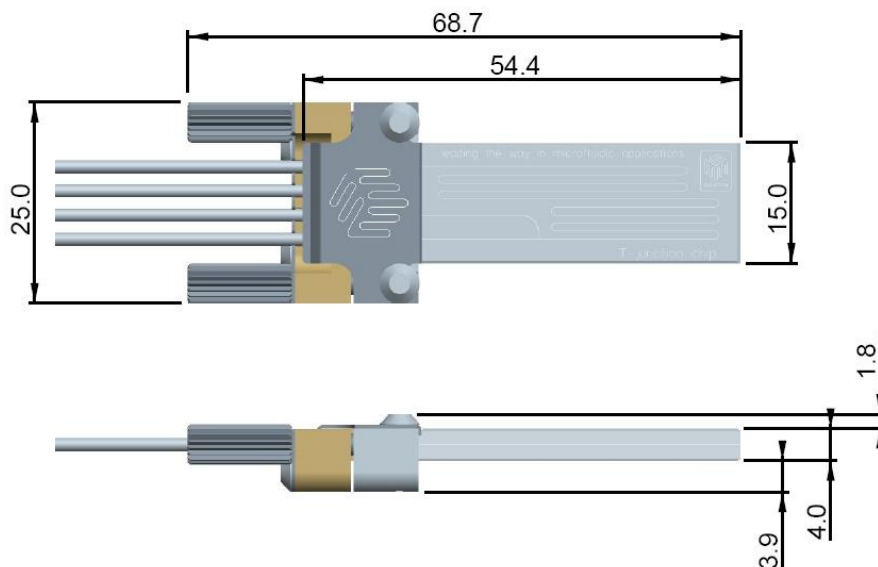

Optical transmission (through glass)

